

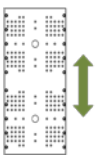
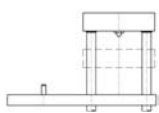
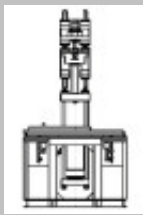

Model: FT-2100DS

- ◆ Double Slide Table
- ◆ Clamping force:213Ton
- ◆ Injection weight:323~483g
- ◆ Vertical clamping and vertical injection design
- ◆ Double Sliding Platen, effective to increase production capacity and machine safety factor.

SPECIFICATION

		DESCRIPTION	UNIT	FT-2100DS		
INJECTION UNIT		Screw Diameter	mm	φ45	φ50	φ55
		Maximum Injection Pressure	kg/cm ²	2292	1856	1534
		Theoretical Shot Volume	cm ³	350	432	522
		Maximum Shot Weight (PS)	g(oz)	323(11.4)	399(14.1)	483(17)
		Injection Rate	cm ³ /sec	118	146	176
CLAMPING UNIT		Top Platen Size	mm	990×940		
		Slide Table Size	mm	695×1900		
		Slide Stroke	mm	950		
		Mold Size	mm	720×670		
		Clamping Force	ton	213		
		Minimum Mold Thickness	mm	350		
		Opening Stroke	mm	450		
		Open Daylight	mm	800		
		Ejector Force	ton	7		
		Ejector Stroke	mm	145		
OTHERS		Hydraulic System Pressure	kg/cm ²	140		
		Oil Tank Volume	L	500		
		Electric Power	hp(kW)	25(18.5)		
		Barrel Heating Power	kW	10.5		
		Total Wattage	kW	29		
		Machine Dimensions (approx.)	m	4.3×1.3×4.6		
		Machine Weight (approx.)	t	9.0		